

E220 AMxD

E220

User Manual



## Revision history

Version	Date	Comments
a	10.01.2018	First edition.
b	16.03.2018	Corrections for MID
c	19.03.2018	Corrections for MID
d	21.03.2018	Corrections for MID
e	18.04.2018	Corrections for National Approval
f	19.04.2018	Corrections for National Approval

---

Although the information contained within this document are presented in good faith and believed to be correct, Landis+Gyr (including its affiliates, agents and employees) disclaim any and all liability for any errors, inaccuracies or incompleteness relating to the product. Landis+Gyr makes no warranty, representation or guarantee regarding the performance, quality, durability or suitability of the products for any particular purpose. To the fullest extent permitted by law Landis+Gyr disclaims (1) any and all liability arising out of the use of the product, (2) any and all liability, including, but without limitation to, special, consequential and indirect damages and losses, and (3) any and all implied warranties, including, but without limitation to, fitness for purpose and merchantability.

The information contained in this document is strictly confidential and is intended for the addressee only. The unauthorised use, disclosure, copying, alteration or distribution of this document or the contents thereof is strictly prohibited and may be unlawful.

All product information are subject to change without notice.

# Table of contents

Revision history .....	2
Table of contents .....	3
About this document .....	5
<b>1 Safety and Regulations .....</b>	<b>6</b>
1.1 Safety information .....	6
1.2 Responsibilities .....	6
1.3 Safety regulations .....	6
1.4 Measurement accuracy remarks .....	7
<b>2 Description of unit .....</b>	<b>8</b>
2.1 General view .....	8
2.2 Functional overview .....	8
2.3 Type designation .....	9
2.4 Technical details .....	10
2.4.1 Overview .....	10
2.4.2 Optical input .....	11
2.4.3 Optical output (INFO interface) .....	11
<b>3 Mechanical construction .....</b>	<b>12</b>
3.1 Case .....	12
3.2 Faceplate markings .....	13
3.3 Control elements .....	14
3.4 Dimensions .....	14
3.5 Connections .....	14
3.5.1 E220 60A direct connected .....	14
3.6 Connection diagrams .....	15
<b>4 Installation .....</b>	<b>16</b>
4.1 Introduction .....	16
4.2 Before installation .....	17
4.3 Mounting .....	17
4.4 Connecting .....	18
4.5 Commissioning and functional check .....	18
4.6 Uninstalling the meter .....	19
<b>5 Operation .....</b>	<b>20</b>
5.1 Display .....	20
5.1.1 Basic layout and symbols .....	20
5.1.2 Billing-relevant line .....	20
5.1.3 Status information on the display .....	21
5.1.4 Information display line .....	22
5.2 Faceplate description .....	22
5.3 Meter configuration .....	23
5.3.1 Mechanical variants .....	23
5.3.2 Faceplate .....	23
5.3.3 Firmware parameters .....	23
5.3.4 Logistics .....	24
5.4 End-user operations .....	24
5.4.1 User menu .....	24
5.4.2 Optical interface: INFO DSS .....	29

5.5	Update.....	29
5.5.1	Crypto reset.....	29
5.5.2	Firmware update.....	30
5.6	Option Modules .....	30
5.6.1	General.....	30
5.6.2	Dual Tariff Module .....	30
5.6.3	LMN-Interface RS485 .....	32
5.6.4	LMN-Interface wM-Bus .....	34
<b>6</b>	<b>Maintenance.....</b>	<b>35</b>
6.1	Service .....	35
6.2	Troubleshooting .....	35
6.2.1	Error codes .....	35
<b>7</b>	<b>Decommissioning and disposal .....</b>	<b>36</b>
<b>8</b>	<b>Terms and abbreviations .....</b>	<b>37</b>
<b>9</b>	<b>Index .....</b>	<b>38</b>

## About this document

**Range of validity** The present User Manual applies to **E220 Series 1** electricity meters. It is valid for the variant:

- E220 AM1D 60 A meter

The manual also describes all measurement modes:

- +A with return stop                      Active plus only
- -A with return stop                      Active minus only
- +A / -A                                      Active plus and active minus
- -A balanced without return stop      Active totalised

**Purpose** The user manual contains all the information required for metering applications for the intended purpose. This includes:

- Provision of knowledge concerning the characteristics, construction and function of the meters
- Information about potential dangers, their consequences and measures to prevent any danger
- Details about the performance of all activities throughout the service life of the meters (parameterisation, installation, commissioning, operation, maintenance, decommissioning and disposal)

**Target group** The content of this user manual is intended for technically qualified personnel of energy supply companies, responsible for system planning, installation and commissioning, operation, maintenance, decommissioning and disposal of meters.

**Reference documents** The following documents provide further information related to the subject of this document:

- D000063493 E220-AMxD Technical Data en

### Typographical conventions

The following typographical conventions are used in this document:

Font	Description
<b>Bold</b>	Font style used for menu items and buttons in the user interface and for keyboard keys.
<i>Italics</i>	Font style used for captions and new terminology.
<code>Courier</code>	Font for file names, paths and code examples.

**Terms and abbreviations** A list of terms and abbreviations used in this document is available at the end of this document.

# 1 Safety and Regulations

## 1.1 Safety information

The following symbols are used to draw your attention to the relevant danger level, i.e. the severity and probability of any danger, in the individual sections of this document.

**Warning**

Used to indicate a dangerous situation that could cause bodily injury or death.

---

**Caution**

Used to indicate a situation/ action that could result in material damage or loss of data.

---

**Note**

Used to indicate general guidelines and other useful information.

---

In addition to the danger level, safety information also describes the type and source of the danger, its possible consequences and measures for avoiding the danger.

## 1.2 Responsibilities

The owner of the meters – usually the utility company – is responsible for assuring that all persons engaged in working with meters:

- Have read and understood the relevant sections of the user manual.
- Are appropriately qualified for the work to be performed.
- Strictly observe the safety regulations (laid down in section 1.3 “Safety regulations”) and the operating instructions as specified in the individual sections.

In particular, the owner of the meters bears responsibility for the protection of persons, prevention of material damage and the training of personnel.

For this purpose, Landis+Gyr provides training on a variety of products and solutions. Contact your local Landis+Gyr representative for more information.

## 1.3 Safety regulations

The following safety regulations must be observed at all times:

- The meter connections must be disconnected from all voltage sources during installation or when opening.
- Contact with live parts can be fatal. The main fuses should, therefore, be removed and kept in a safe place until the work is completed so that other persons cannot replace them unnoticed.
- Local safety regulations must be observed. Only technically qualified and appropriately trained personnel are authorised to install the meters.

- Only appropriate tools shall be used for the job. This means, e.g. that the screwdriver must be of the correct size for the screws, and the handle of the screwdriver must be insulated.
- The meters must be held securely during installation. They can cause injuries if dropped.
- Meters that have been dropped must not be installed, even if no damage is apparent, but must be returned to the service and repair department (or the manufacturer) for testing. Internal damage may result in malfunctions or short-circuits.
- The meters must never be cleaned under running water or with compressed air. Water ingress can cause short-circuits.

## 1.4 Measurement accuracy remarks

For the devices described here, the MessEV §17, paragraph (4) applies.



### Note

When connected to a Smart-Meter-Gateway, measured values of the meter may only be used for billing purposes if the voltage supply is from the uncounted area of the Smart-Meter-Gateway conforming to the MessEV.

---



### Note

Historical energy registers and momentary values for these exclusively informative purposes and may not be used for billing purposes.

---

## 2 Description of unit

### 2.1 General view



Figure 1. General view of the device

### 2.2 Functional overview

E220 is a smart meter ready electricity meter offering reliable performance with versatile functionality. It is designed close to the FNN specification for base meters for the German Smart Meter rollout. Missing parts are DIN rail, module cover and power supply for the gateway. LMN communication is using RS-485 or wireless M-Bus technology and enables integration with intelligent Metering System (iMsys).

The E220 is available in the following meter variant:

- E220 AM1D 60 A meter

The meter can be configured to one of the following measurement modes during the manufacturing process:

- |                                   |                              |
|-----------------------------------|------------------------------|
| • +A with return stop             | Active plus only             |
| • -A with return stop             | Active minus only            |
| • +A / -A                         | Active plus and active minus |
| • -A balanced without return stop | Active totalised             |



## 2.3 Type designation

Example	E	220	-	A	M	1	D.	A	3	A.	A	0	-	S	0	0	-	S1
<b>Brand name</b>	E220 Residential smart meter																	
<b>Product family</b>	A Product family residential																	
<b>Network and mechanical standard</b>	M 3-phase, 4-wire DIN																	
<b>Maximum current</b>	1 Maximum current 60A																	
<b>Voltage level</b>	D 230V phase – neutral / 400V phase – phase																	
<b>Measurement modes</b>	A Active, no reactive; vector value measurement																	
<b>Measurement modes 2</b>	<ul style="list-style-type: none"> <li>1 +A with return stop; active plus only</li> <li>2 -A with return stop; active minus only</li> <li>3 +A / -A; active plus and minus</li> <li>4 -A balanced without return stop; active totalised</li> </ul>																	
<b>Additional quantities</b>	A Energy only																	
<b>Accuracy active measurement</b>	A Class A (MID)																	
<b>Accuracy reactive measurement</b>	0 No reactive measurement																	
<b>Basic meter measurement</b>	S SLP Standard Load Profile																	
<b>Tariffication</b>	0 optional,																	
<b>LMN-interface</b>	0 optional																	
<b>Hardware series</b>	S1 Series 1																	

## 2.4 Technical details

### 2.4.1 Overview

#### Architectural overview

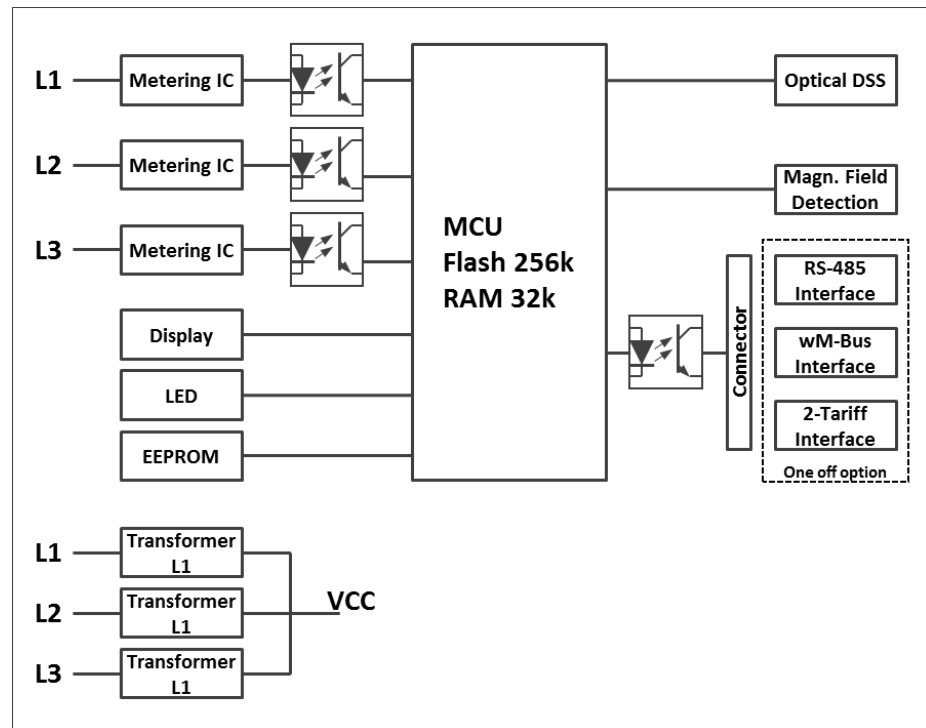

Figure 2. Architectural overview

#### Measurement technology

The measurement technology used in the E220 meters is based on current shunts. Three measuring elements (one for each phase) measure the phase currents using shunts, and the phase voltages over a resistor divider. The analogue/digital converters transform both signals into digital voltage and current data. This data is then fed into the microprocessor, which produces the energy proportional values and adds the value to the corresponding values of the other phases. The sum is then transferred into the corresponding energy registers.

#### Power supply

The supply voltage for the meter electronics is taken from the three-phase system. The meter will work correctly as soon as neutral and at least one phase are connected to mains voltage. In the event of mains failure, a voltage monitor ensures the safe storage of meter data and manages the restart when mains voltage is restored.

#### Memory

Meter parameters are stored in a non-volatile (Flash) memory, which protects the parameters in the event of power failure.

#### Seconds counter

The meter features a seconds index counter. The seconds index counter starts at 0 the first time the meter firmware is run, and will, from this moment on, be incremented by 1 every second. In the event of voltage loss, the seconds counter at the time of voltage loss will be saved. When restarting the firmware after voltage recovery, the seconds counter will resume operation with the reading at

the moment of voltage loss incremented by 1. In all operating situations, the counter never jumps backwards, but will always increase in a strictly monotonous manner.

### Summation method

Vector summation (mode A) for 3-phase 4-wire summation over all phases is done as follows:

Calculation method	Example 1	Example 2
+A with return stop		
-A with return stop		
+A / -A		
-A balanced without return stop		

### 2.4.2 Optical input

Optical INFO interface is used to communicate with the meter. The meter is set to the menu mode using a flashlight.

The illuminance of the flashlight must be at least 400 lux.

### 2.4.3 Optical output (INFO interface)

The E220 has a unidirectional optical interface. It is designed according the DIN EN 62056-21 standard. The optical interface is located in the upper right corner of the faceplate.

The meter pushes a defined set of values every second to the optical interface.

## 3 Mechanical construction

### 3.1 Case

The meter case is made of antistatic plastic (polycarbonate). The LCD display, the optical interface and the pulse output LED are always visible. The DIN rail is made in plastic as well. Installed modules must be covered by a sealable module cover. Mains power for the gateway is located under the sealable terminal block cover.

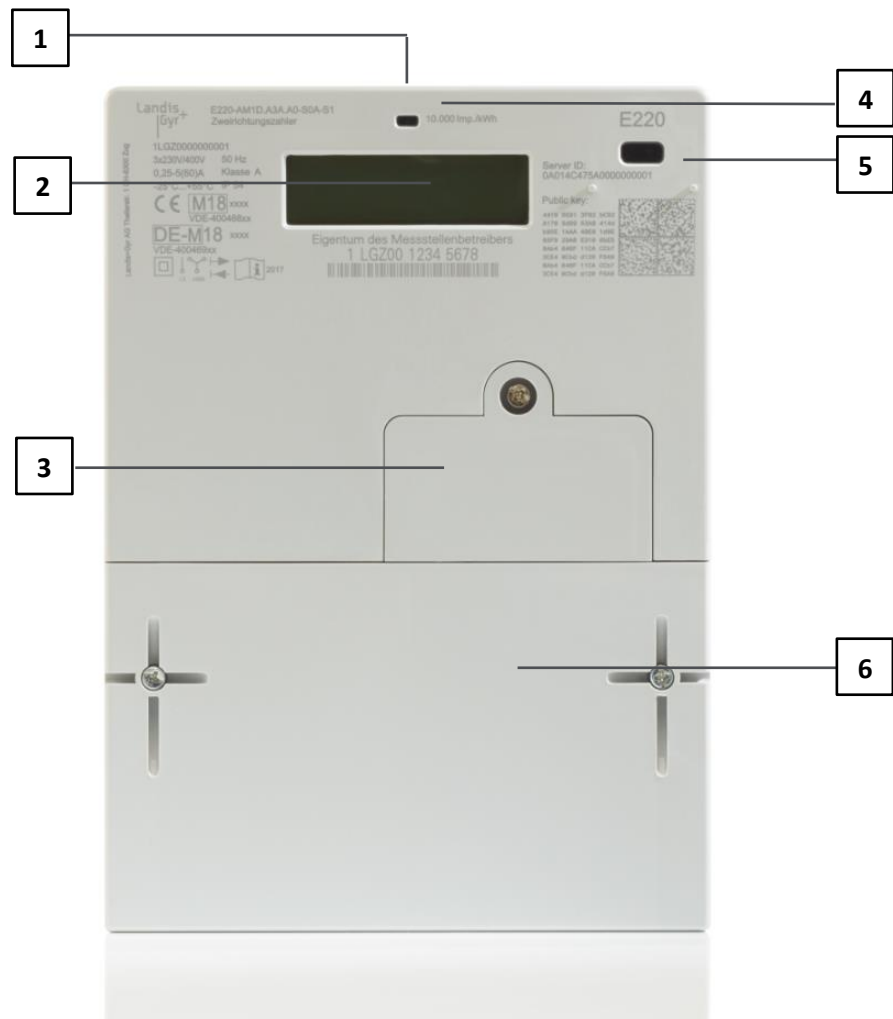

Figure 3. Meter case

- 1 Flexible hook
- 2 LCD display
- 3 Module slot
- 4 Pulse output LED (metrological LED)
- 5 Optical interface
- 6 Terminal cover

### 3.2 Faceplate markings

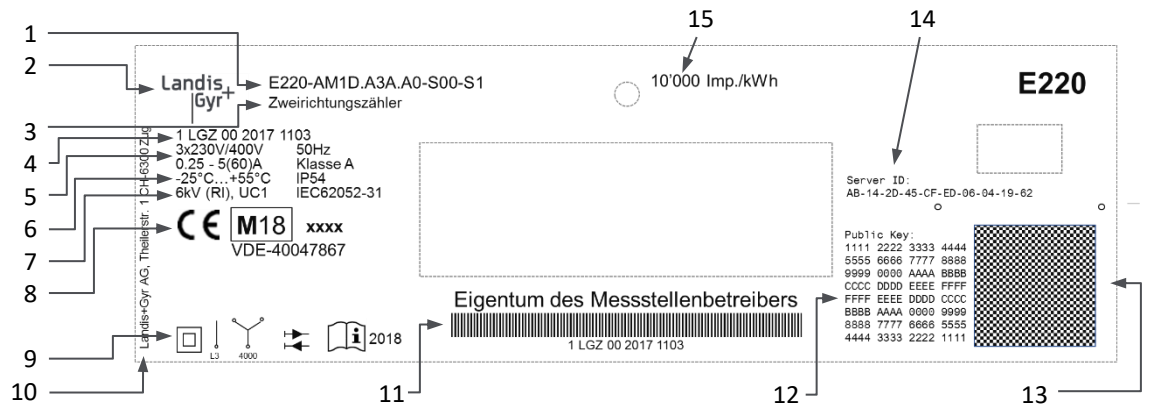

Figure 4. Faceplate markings

- 1 Meter type designation
- 2 Brand name
- 3 Measurement mode:
  - Einrichtungszähler +A = +A with return stop
  - Einrichtungszähler -A = -A with return stop
  - Zweirichtungszähler = +A / -A
  - Saldierender Zähler -A = -A balanced without return stop
- 4 Unique device ID manufacturer serial number (14 characters) according DIN 43863-5
- 5 Nominal connection values (voltage, frequency, current range)
- 6 Accuracy class active energy, if appropriate accuracy class reactive energy
- 7 Nominal operating temperature range
- 8 CE conformity, metrological approval, EU type examination certificate
- 9 Symbols:
  - Isolation
  - Measurement mode
  - Calibrated single-phase meter
  - Calibrated three-phase meter
  - Read User Manual
  - Year of calibration
- 10 Manufacturer address
- 11 Property plate
- 12 Public key NIST curve
- 13 2-D barcode including: manufacturer serial number, device ID, server ID, public key
- 14 Server ID
- 15 Impulse constant of pulse output LED

### 3.3 Control elements

The E220 meter has as a single control element, the optical interface. This interface is used by the end-user to communicate with the device.

### 3.4 Dimensions

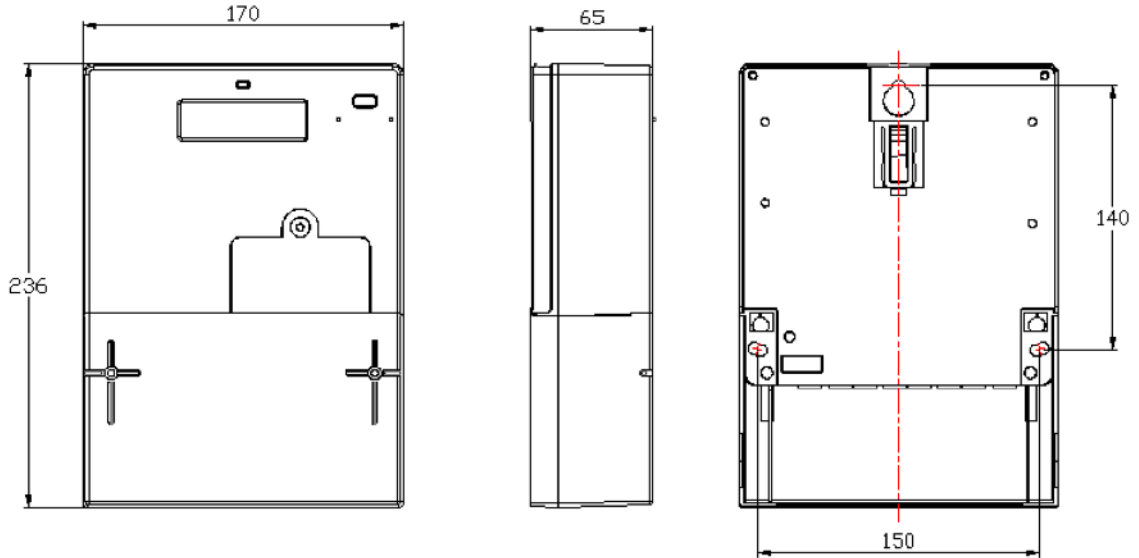

### 3.5 Connections

#### 3.5.1 E220 60A direct connected

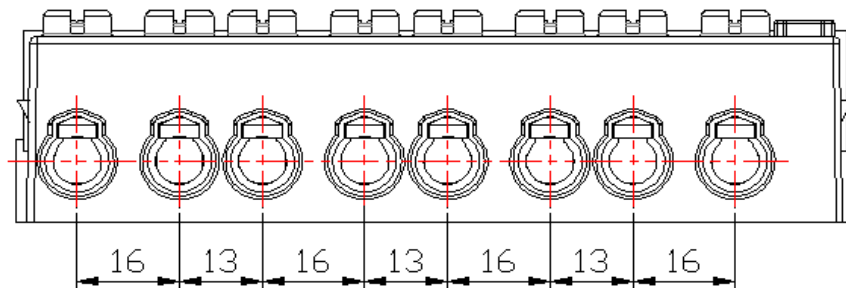

Terminal type	Cage clamp terminal
Maximum wire diameter	7.0 mm
Minimum wire diameter	1.5 mm
Screw head	Pozidrive No. 2

### 3.6 Connection diagrams

According to the German standard DIN 43856, connection and circuit diagrams are defined with numbers.

#### Direct connected meters

Direct connected meters (4-wire) are connected as follows:

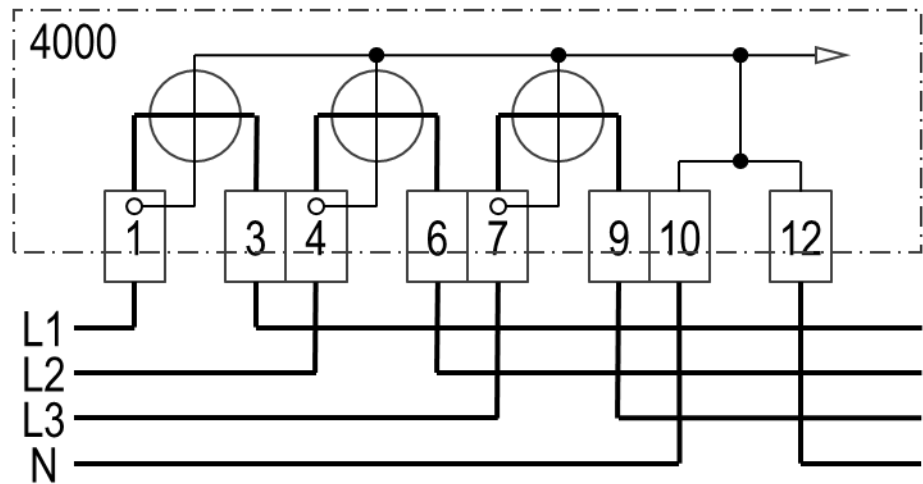

Figure 5. DIN 43856 Electricity meters, tariff time switches and ripple control receivers. Diagram number 4000

## 4 Installation



### Do not touch live parts

Dangers can arise from live electrical installations to which the meters are connected. Touching live parts is dangerous to life. All safety information should therefore be strictly observed.

### Intended environmental conditions for meter installations:

- The meter is intended to be installed in a mechanical environment “M1”, with shock and vibrations of low significance, as per directive 2014/32/EU.
- The meter is intended to be installed in electromagnetic environment “E2”, as per directive 2014/32/EU.
- The meter is intended to be installed indoors in non-condensing humidity conditions.
- The meter should be installed with copper conductors. The use of aluminium conductors may result in corrosion. Seek advice from Landis+Gyr before using this meter with aluminium conductors.
- The installation site must meet the requirements of:
  - The meter’s ingress protection rating (IP54) and
  - The operating temperature range (-25°C ... +55°C).
- Avoid installing the meter on south-facing walls and in direct sunlight. If necessary, use an additional shield or visor to protect the installation from direct sunlight (shield not provided by Landis+Gyr).



### This meter is intended for indoor use only

In cases where an outdoor installation is unavoidable, care must be taken to ensure the meter is installed within a suitable enclosure to maintain the operating environment in accordance with the meter specification. Such enclosures must be securely sealed to avoid the risk of meter damage as a consequence of exposure to the external environment including (but not limited to) extreme temperatures, humidity and insect ingress.

### 4.1 Introduction

The following conditions must be met for installation and commissioning of the meter:

- The work described below must only be conducted by technically qualified and suitably trained persons.
- These persons must be familiar with and observe the local safety regulations.
- Strict observance of the details contained in section 1 “Safety”, in particular the safety regulations, as well as safe operation.
- Before starting work, ensure that the materials and tools required are all present.



## 4.2 Before installation



### **Dangerous voltage on conductors**

The connecting wires at the place of installation must not be live when fitting the meter. Touching live parts is dangerous to life. The main fuse should be removed and kept in a safe place until work is completed, so that it cannot be replaced by anyone unnoticed.

---



### **No overcurrent protection or automatic disconnection**

As the meter has no internal overcurrent protection and no method of disconnection from the mains, this must be provided by the end installation.

---

## 4.3 Mounting



### **Observe safety instructions**

Prior to starting the mounting of the meter, read and strictly observe the general safety instructions given in section 4.2 “Before installation”.

---



### **Observe E VDE-AR-N 4101:2014-03**

Requirements for metering points in electrical installations in the low voltage network.

---

The meter should be mounted as follows on the meter board or similar device provided for this purpose (see also section 3.4 “Dimensions”):

1. Find the correct position for the meter. Ensure there are no wires underneath the holes to be drilled.
2. Determine the desired type of mounting (open or covered mounting).
3. For covered mounting, use the fixed bracket at the back of the meter. For open mounting, move the mounting bracket (provided with the unit) to the top of the meter. See the following figure.

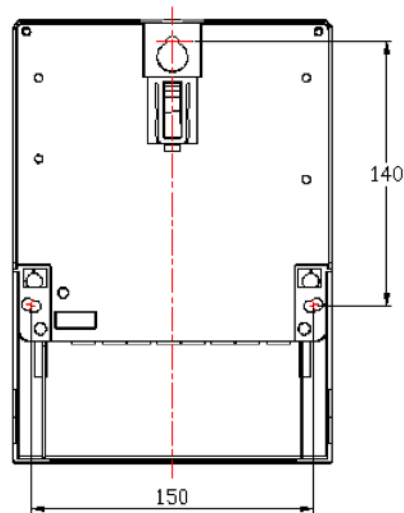

Figure 6. Mounting bracket location at the back of the meter (standard terminal cover and long terminal cover)

## 4.4 Connecting

Before putting the meter into operation, the following items must be checked and corrected, if necessary:

1. Has the correct meter (with correct identification number) been installed at the measuring point of the relevant consumer?
2. Are all thrust screws for the phase connections and neutral tightened sufficiently?
3. Are the mains inputs and outputs connected correctly? The conductor from the house connection or from the main fuse must be present at the input, those of the meter to the consumer at the output.
4. Is the neutral conductor connected to terminal 10?
5. Attach the terminal cover.
6. Close the terminal cover with screws.
7. Check the installation as described in section 4.5 “Commissioning and functional check”.

## 4.5 Commissioning and functional check

The installed meter should be checked and put into service as follows:

1. Insert the main fuses removed before installation. The meter is switched on.
2. After 2 seconds, the display lights up with the display test. It shows all segments of the upper line and the lower line for 2 seconds each. This sequence is repeated three times.
3. The upper line shows the OBIS code 0.2.0 for firmware version, the lower line shows the firmware version.
4. The upper line shows the OBIS code C.90.2 for firmware checksum, the lower line shows the firmware checksum.
5. Check the display for error messages and connect a load.

6. Check that the meter is measuring correctly. Display indicators and their functions are described in section 5.1 “Display”.

## 4.6 Uninstalling the meter



### Remove main fuse before disconnecting

The connecting wires at the place of installation must not be live when removing the meter. Touching live parts is dangerous to life. The corresponding main fuse must be removed and kept in a safe place until work is completed, so that it cannot be replaced by anyone unnoticed.

---

Remove the meter from the mains network as follows:

1. Switch off the voltage by detaching the main fuse. The display goes off.
2. Remove the seals from terminal cover screws.
3. Release and remove the terminal cover.
4. Ensure with a phase checker that the connecting wires have no voltage. If there is voltage, remove the main fuses.
5. Remove the connecting wires of the auxiliary inputs and outputs, if available.
6. Loosen the terminal screws of the phase and neutral connecting wires with a suitable screwdriver and withdraw the wires from the terminals.
7. Unscrew and remove the meter.
8. Fix a replacement meter with the three fixing screws on the mounting surface.
9. Connect the replacement meter as described in section 4.4 “Connecting” and the following sections.

# 5 Operation

## 5.1 Display

### 5.1.1 Basic layout and symbols

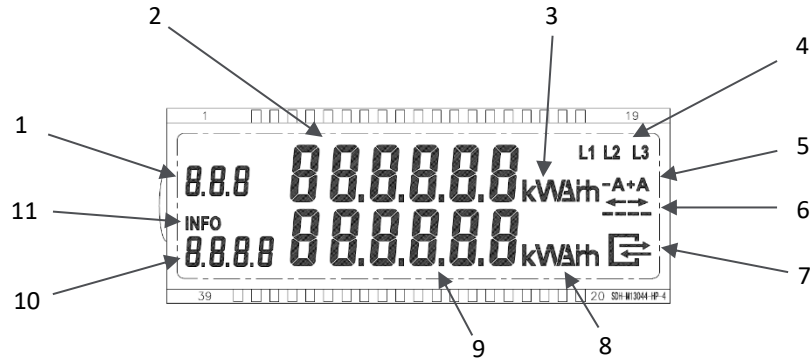

Figure 7. Basic display layout and symbols

**Billing-relevant:**

- 1 OBIS code
- 2 Value field
- 3 Energy measurement units

**Status information:**

- 4 Phase voltage presence indications
- 5 Energy direction
- 6 Simulation of rotating disk
- 7 Status of LMN communication (Only relevant with option LMN-interface RS-485)

**Information display:**

- 8 Measurement units
- 9 Value field
- 10 Value code
- 11 Info for running pushes on optical INFO interface

### 5.1.2 Billing-relevant line

The following tables show a list of commonly used OBIS codes. The display list of the E220 meter depends on the measurement mode.

**+A with return stop (Einrichtungszähler +A)**

Upper line

OBIS code	Value
F.F.	Error code (see section 6.2.1 "Error codes")
1.8.0	Active energy +A (import), total

**-A with return stop (Einrichtungszähler -A)**

Upper line

OBIS code	Value
F.F.	Error code (see 6.2.1 "Error codes")
2.8.0	Active energy -A (export), total

**+A / -A (Zweirichtungszähler)**

Upper line

OBIS code	Value
F.F.	Error code (see 6.2.1 "Error codes")
1.8.0	Active energy +A (import), total
2.8.0	Active energy -A (export), total

**-A balanced without return stop (Saldierender Zähler -A)**

Upper line

OBIS code	Value
F.F.	Error code (see section 6.2.1 "Error codes")
2.8.0	Active energy -A (export), total

**5.1.3 Status information on the display****Phase voltage presence indications**

If phase L1, L2 or L3 is present, the corresponding segment lights up. The threshold is  $0.8 U_n$ .

**Energy direction**

-A or +A represents the actual energy direction. An additional arrow is also lit on below the corresponding A sign.

**Simulation of rotating disk**

The four horizontal bars simulate the rotating disk of Ferraris meters. The disk always runs left to right regardless of the energy direction. With each pulse of the pulse output LED (metrological LED), the rotating disk switches to the next segment.

**Status of LMN communication**

The symbol is relevant only with LMN-Module plugged-in. It represents the different statuses of the LMN interface:

Symbol	Status
OFF	No communication on LMN interface
Blinking 0.5s on/0.5s off	Any layer 2 telegrams detected
Blinking	HDLC connection telegrams detected

Symbol	Status
2s on/ 2s off	
ON	TLS connection ready. The meter communicates in secure mode.

### 5.1.4 Information display line

#### Measurement units

Lower line

OBIS-Code	Value
P	Instantaneous power balance +A – -A (if enabled)

#### Value field and value code

Field for displaying instantaneous power.

#### Info for running pushes on optical INFO interface

The INFO symbol indicates to the end-user that the second line is for information purposes only. It also indicates data pushes on the optical INFO interface.

## 5.2 Faceplate description

#### Device ID

The Device ID is a unique identifier according the DIN 43863-5 standard. The 14 characters are defined as follows:

14	13	12	11	10	09	08	07	06	05	04	03	02	01	Characters total
Section	Manufacturer			Production bloc		Serial number							Description	
1	L	G	Z	0	0	6	3	5	3	9	4	2	1	Identifier
OBIS	DLMS (FLAG)			Production bloc		Serial number							Description	

The first character represents the branch according the OBIS code. For electricity meters it is a "1".

Characters 2 to 4 represent the manufacturer. In our case "LGZ".

Manufacturer block is "00".

The last 8 characters are the manufacturer serial number.

#### 2D barcode

The 2D barcode is according ISO/IEC 16022:2000 and ISO/IEC 24720:2006. The 2D barcode includes:

- Prefix AA: Device ID
- Prefix AB: Server ID
- Prefix AC: Public key

See also FNN-Dokument "Data Matrix Code für Messeinrichtungen und Komponenten für Messsysteme".

## Server ID

At the optical INFO interface, data is pushed in SML (Smart Message Language). The server ID is part of the SML response. The server ID is derived out of the device ID.

## Public key NIST curve

TLS communication on LMN needs the NIST curve. The public key of the meter is printed on the faceplate.

## 5.3 Meter configuration

The initial configuration of the meter is defined when ordering the meter from Landis+Gyr.

### 5.3.1 Mechanical variants

Parameter	Values
Meter variants	<ul style="list-style-type: none"> <li>▪ E220 – 60A, 0.25-5 (60) A</li> </ul>
Module slot	<ul style="list-style-type: none"> <li>▪ Dummy cover (Standard)</li> <li>▪ LMN-interface RS-485 pre-installed</li> <li>▪ LMN-interface wM-Bus pre-installed</li> <li>▪ 2-Tariff-Module pre-installed</li> </ul>
Terminal cover	<ul style="list-style-type: none"> <li>▪ Standard terminal cover (60 mm space)</li> <li>▪ Long terminal cover (80 mm space)</li> </ul>

### 5.3.2 Faceplate

Parameter	Values
Property Plate	<ul style="list-style-type: none"> <li>▪ Property plate, standard</li> <li>▪ Property plate, customer-specific</li> </ul>

### 5.3.3 Firmware parameters

Parameter	Values
Measurement mode	<ul style="list-style-type: none"> <li>▪ +A with return stop; active plus only</li> <li>▪ -A with return stop; active minus only</li> <li>▪ +A / -A; active plus and active minus</li> <li>▪ -A balanced without return stop; active power totalised</li> </ul>
Signature curve	<ul style="list-style-type: none"> <li>▪ NIST P-256</li> <li>▪ Brainpool</li> </ul>
PIN protection	<ul style="list-style-type: none"> <li>▪ With PIN protection</li> <li>▪ Without PIN protection</li> </ul>
Active power	<ul style="list-style-type: none"> <li>▪ Not shown in the 2nd line</li> <li>▪ Shown in the 2nd line</li> </ul>
End-user settings at power-down	<ul style="list-style-type: none"> <li>▪ Save end-user data protection settings at power-down</li> <li>▪ Reset data protection settings at power-down</li> </ul>

### 5.3.4 Logistics

Parameter	Values
Packaging variant	<ul style="list-style-type: none"> <li>▪ Single boxes</li> <li>▪ Layers in gitter boxes</li> </ul>

## 5.4 End-user operations

### 5.4.1 User menu

Using the optical button, the end-user can enter the User menu. The menu has the following menu items.

Menu ID	Displayed information
	Display test Upper line Lower line
Pin	Enter the PIN code
P	Instantaneous power
E	Total energy since last reset
1d	Energy (consumption/delivery) last day
7d	Energy (consumption/delivery) last 7 days (week)
30d	Energy (consumption/delivery) last 30 days (month)
365d	Energy (consumption/delivery) last 365 days (year)
HIS	Reset historical values
InF	Push reduced data set or extended data set
Pin	Activate/deactivate PIN code



#### Note

Historical energy registers and momentary values for these exclusively informative purposes and may not be used for billing purposes.

### Optical button

The optical button has two actions:

- Short push or flash with a flashlight (shorter than 2 seconds)
- Long push or flash with a flashlight (longer than 5 seconds)

After a period of 120 seconds without any action on the optical button, the meter will fall back to the standard display (rolling list in case two energy registers are available).



5.4.1.1 Enter PIN

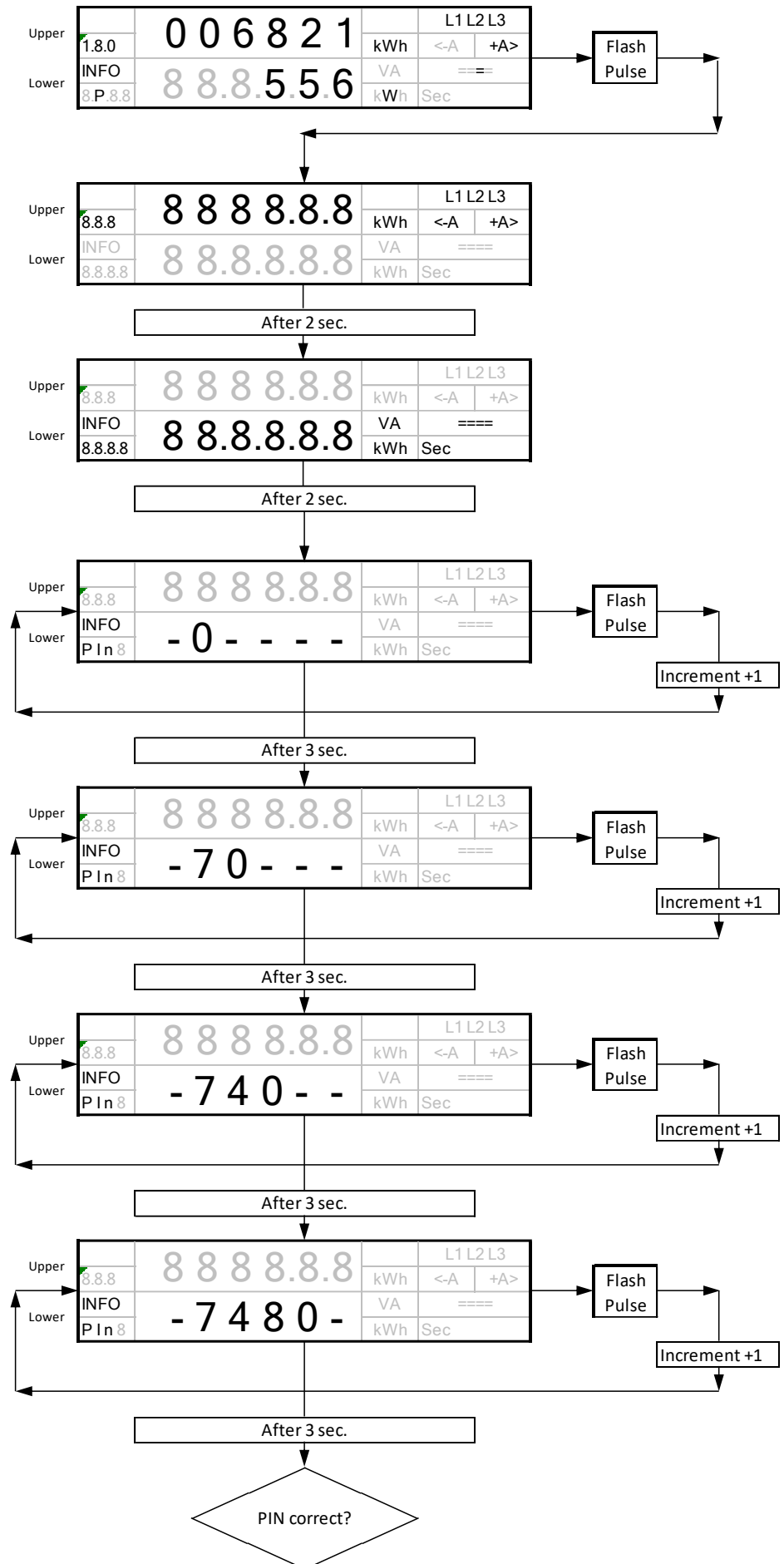

### 5.4.1.2 Instantaneous power

If the PIN is not accepted, the meter switches back to the standard display.

If the PIN is accepted, the meter switches to display the instantaneous power on the lower line.

### 5.4.1.3 Total energy since last reset

With a short flash, the menu switches to total energy since last reset. With further short pulses, the menu switches to historical values, and with long pulses the total energy register may be reset.

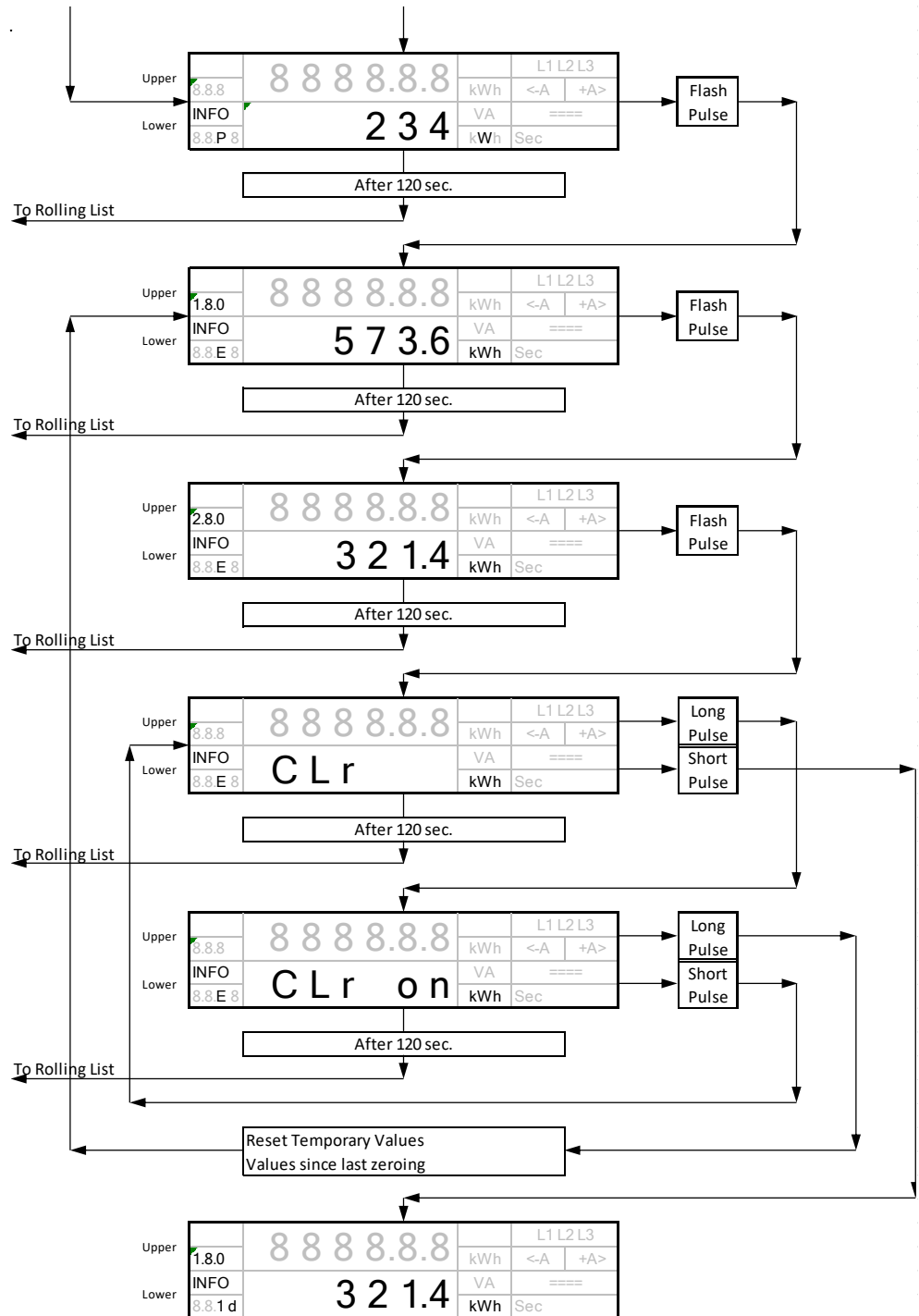

### 5.4.1.4 Historical values

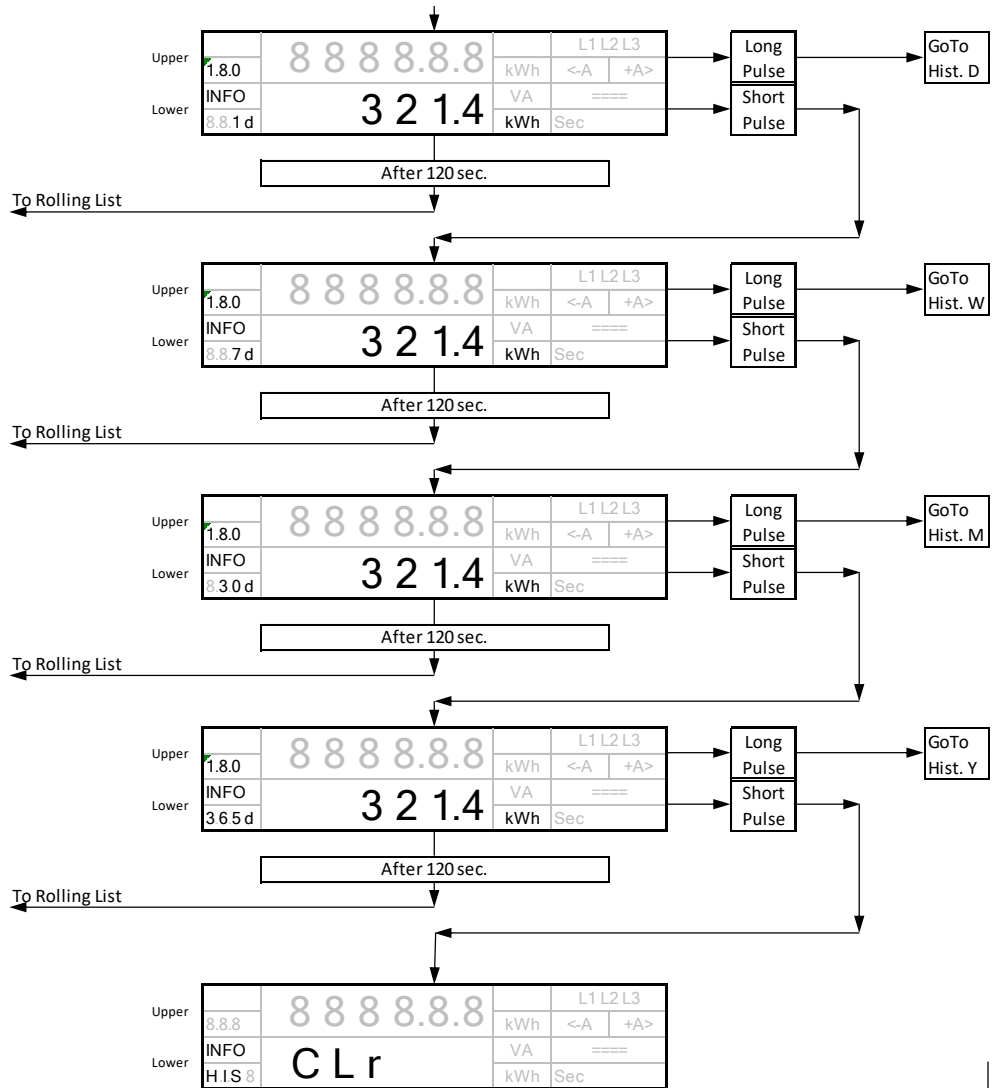

With short flashes, the menu switches to the next duration values. With long flashes, the menu switches to historical values.

### 5.4.1.5 Reset historical values

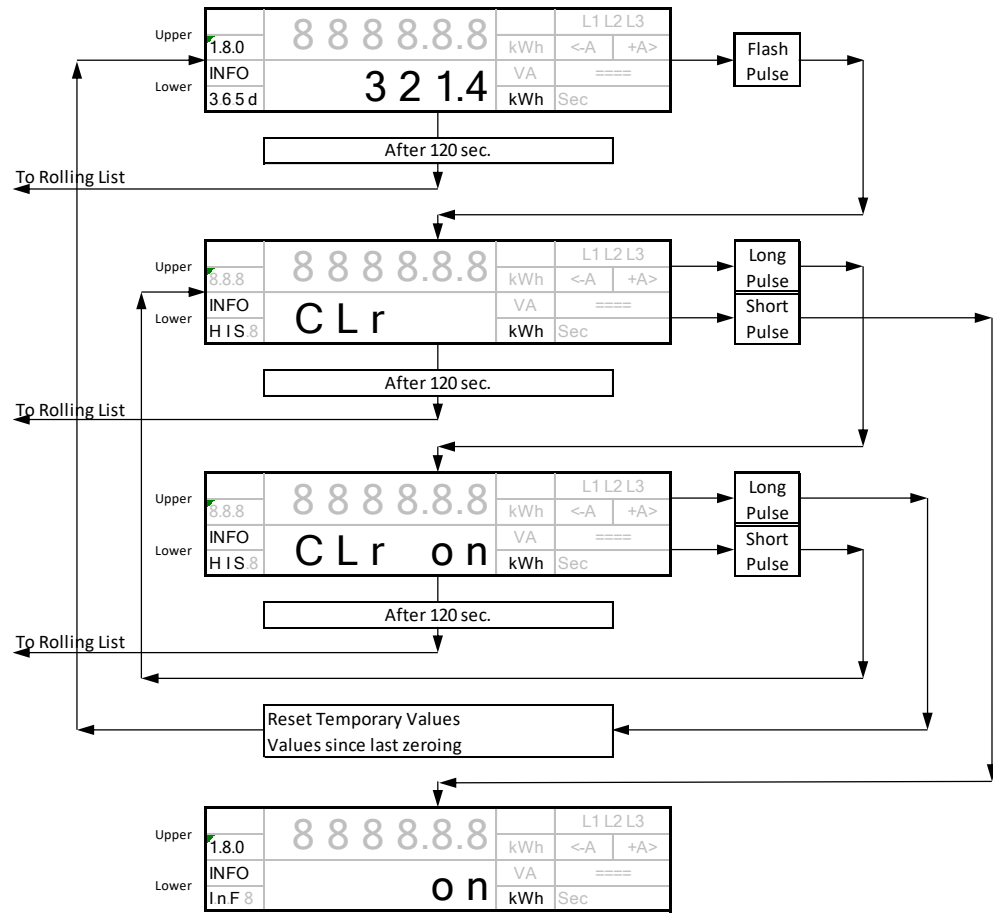

### 5.4.1.6 Data set on INFO DSS

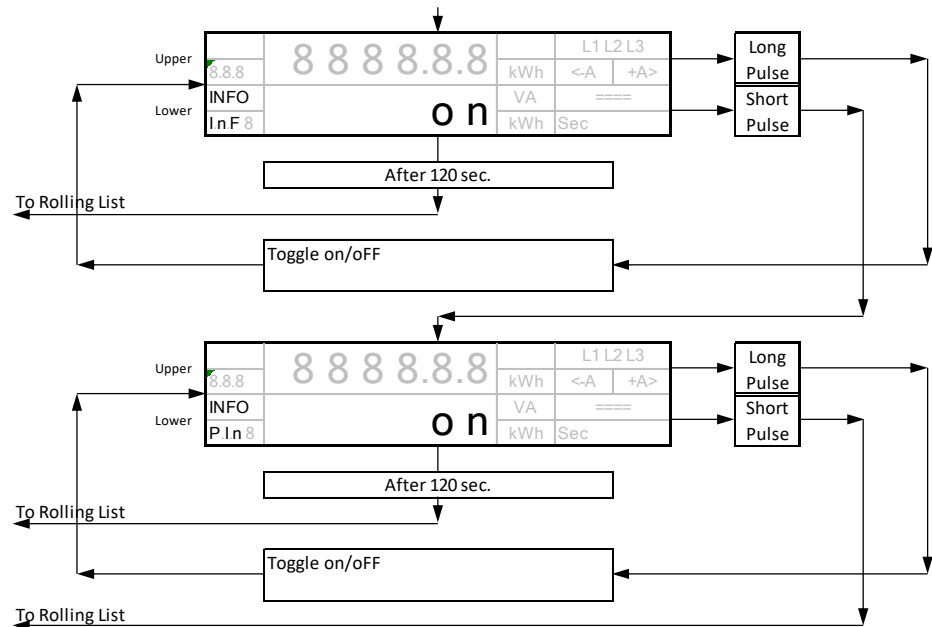

On: Extended data set

Off: Reduced data set

### 5.4.1.7 PIN activation

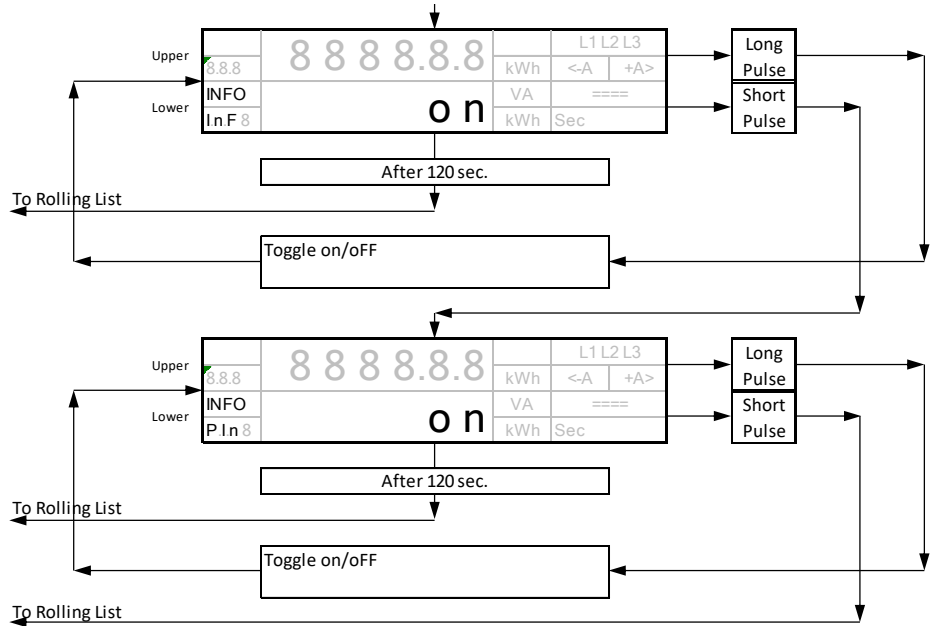

On: PIN activated, instantaneous power not displayed on lower line.

Off: PIN disabled, instantaneous power displayed, if enabled.

### 5.4.2 Optical interface: INFO DSS

#### Data pushes

The optical INFO interface operates in two modes: standard and extended. It pushes the following data periodically every second.

- Manufacturer identification
- Device identification
- Meter reading for +A (if present)
- Meter reading for -A (if present)
- Instantaneous power (if activated)

#### Communication parameters

The communication channel has the following parameters:

- Bitrate 9600 Baud
- Code 8-N-1

## 5.5 Update

### 5.5.1 Crypto reset

The command “Reset the cryptographic parameters” will reset E220 meters to the customer-specific default values with regard to these parameters. The command can be only executed with LMN-Module plugged-in with RS-485 Interface.

This reset causes the following actions to be performed in the E220 meter:

- The symmetrical key for the exchange of TLS certificates is set to the delivery state (the register “Operational key” is thereby set to “Initial key”).

- All TLS certificates and temporary TLS properties including session keys are explicitly headed by '0x00...00'.
- The transmission counter (see FNN LMN requirements for symmetric encryption for the exchange of TLS certificates) will not be reset.
- The state "Operation in a secured SMGW environment" is given up.

The command "Reset the cryptographic parameters" can only be executed, if certain conditions are fulfilled. The time "Tclosed" is set to 30 seconds.

### 5.5.2 Firmware update

Firmware updates are not possible!

## 5.6 Option Modules

### 5.6.1 General

The E220 meter has upon the terminal bloc a module slot. In standard delivery the module slot is covered with a dummy cover. In this case, the meter operates as a standalone 1-tariff meter.



#### **Change modules in power OFF mode only**

To place or replace a module always disconnect the meter from power.

---

### 5.6.2 Dual Tariff Module

To plug-in the 2-Tariff-Module in the E220 the power must be switched off. After power-on, the meter switches to the dual tariff mode.

As soon the meter operates in 2-tariff mode, it writes in registers x.8.1 and x.8.2. The corresponding registers in the rolling list are displayed in the display with the corresponding OBIS code (see also 5.1.1 "Structure of the standard display and symbols"). The OBIS code of the respective active register flashes (0.25 s off / 0.75 s on).

In the background, the register x.8.0 continues to add up as a sum of x.8.1 + x.8.2.

There are four different types of 2-tariff module for a different control of tariffing. By means of predefined PIN coding in the module (factory setting), the meter automatically switches to the correct rating variant.

The basic variant of the meter (consumption, generation or bidirectional meter) defines the presence of the total registers in the meter (+ A: 1.8.0; -A: 2.8.0). The 2-tariff module can only operate with existing total register.

There are four different variants of the Dual Tariff Module:

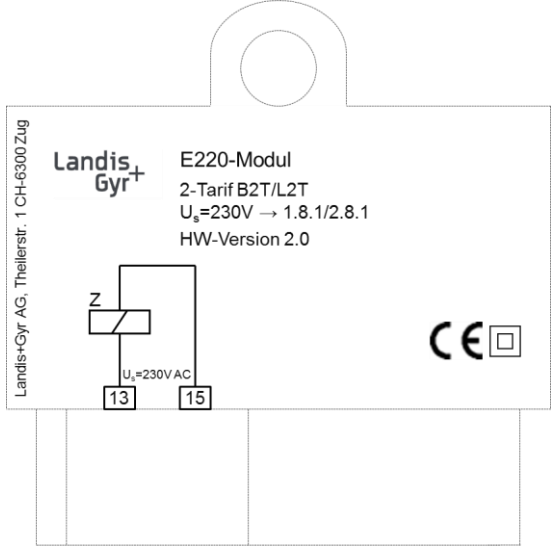
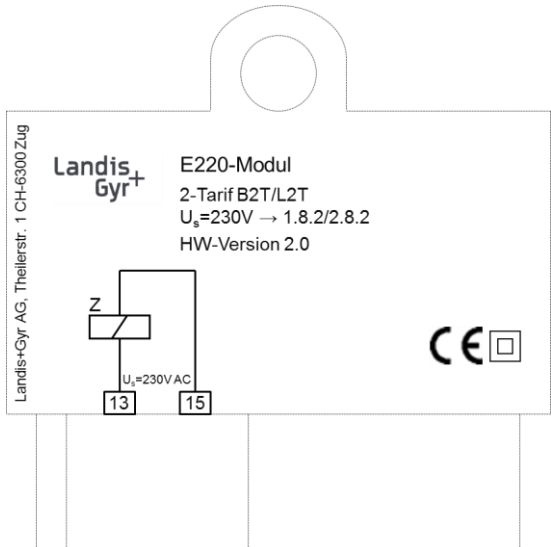
Module-Type	Description
Module B2T/L2T 230V (x.8.1)	Consumption 2-Tariffs, Generation 2-Tariffs Us=230V → 1.8.1, 2.8.1 Us=0V → 1.8.2, 2.8.2 
Module B2T/L2T 230V (x.8.2)	Consumption 2-Tariffs, Generation 2-Tariffs Us=0V → 1.8.1, 2.8.1 Us=230V → 1.8.2, 2.8.2 

Module-Type	Description
Module B2T/L1T 230V (1.8.1)	Consumption 2-Tariffs, Generation 1-Tariff $U_s=230V \rightarrow 1.8.1, 2.8.0$ $U_s=0V \rightarrow 1.8.2, 2.8.0$
Module B2T/L1T 230V (2.8.2)	Consumption 2-Tariffs, Generation 1-Tariff $U_s=0V \rightarrow 1.8.1, 2.8.0$ $U_s=230V \rightarrow 1.8.2, 2.8.0$

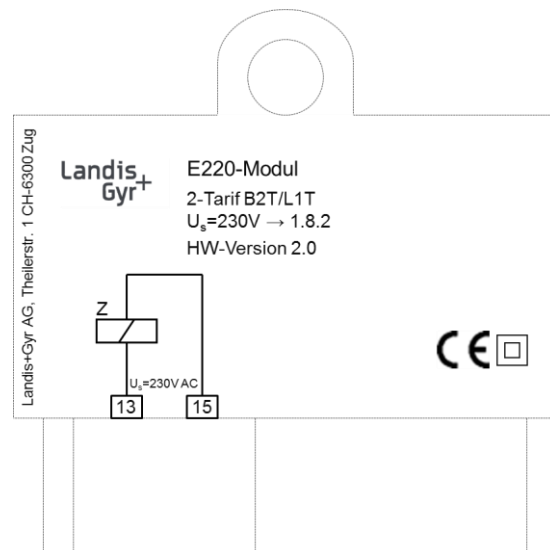
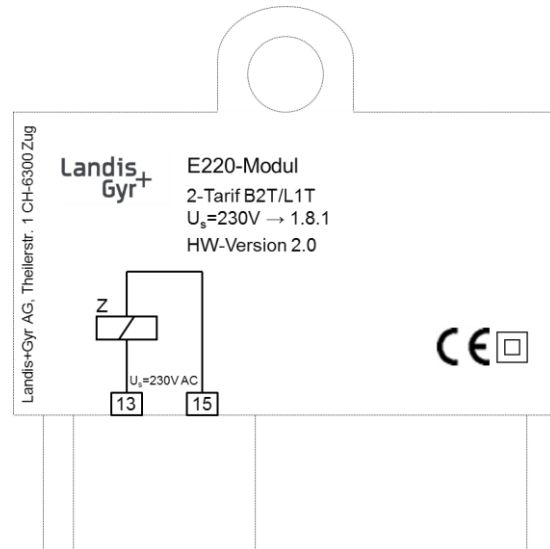

### 5.6.3 LMN-Interface RS485

The Smart Meter Gateway communicates in the LMN (Local Measurement Network) with one or more connected meters to get the values. The meters are either wired or wireless connected.



#### Usage of LMN- Modules

Only LMN-Modules which are referred in the Type Approval document may be placed in the slot.





### Authenticity of LMN- Modules

Only LMN-Modules which are sealed with an appropriate and complete label may be placed in the slot. See picture below.



The applications at the LMN interface are categorized as follows:

1. LMN meter administration
  - a. Registering / Configuration
  - b. Key / Certificate Management
2. Request and receive of meter values
  - a. Single request of meter values
  - b. Multiple request of meter values

In the display the actual status of the LMN-communication is shown. The symbol represents the different statuses of the LMN interface:

Symbol	Status
OFF	No communication on LMN interface
Blinking 0.5s on/0.5s off	Any layer 2 telegrams detected
Blinking 2s on/ 2s off	HDLC connection telegrams detected
ON	TLS connection ready. The meter communicates in secure mode.

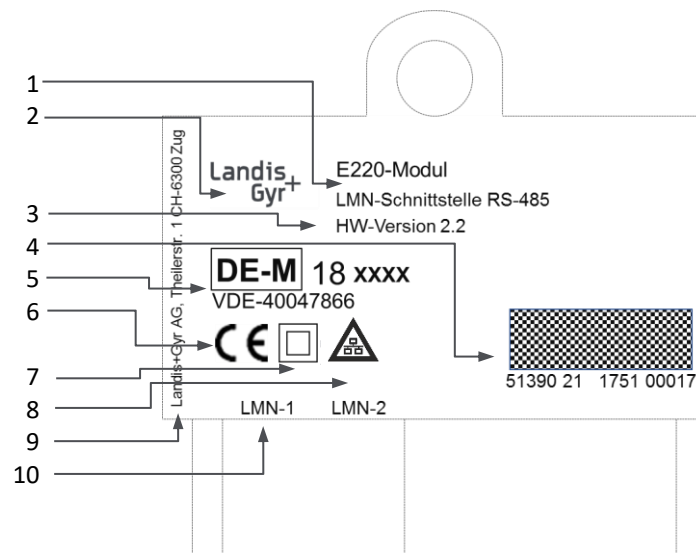

- 1 Type of Communication adapter
- 2 Brand name
- 3 Version number of the HW
- 4 Unique device ID
- 5 German national type approval certificates
- 6 CE conformity
- 7 Isolation
- 8 Network-Access
- 9 Manufacturer address
- 10 Connectors

#### 5.6.4 LMN-Interface wM-Bus

To be defined later

## 6 Maintenance

### 6.1 Service

The E220 meter has no serviceable parts. Device service is available from the local Landis+Gyr representative.

### 6.2 Troubleshooting

If the meter is not operating correctly, check the error displays and LED (see section 5.1 “Display” for instructions on how to use the display). If there is a problem with meter operation, the following points should be checked first:

1. Is the mains voltage present (check meter display)?
2. Has the maximum ambient temperature been exceeded?
3. Is the meter visibly damaged?
4. Is there any error code on the display (code F.F.)? The error codes are described in section 6.2.1 “Error codes”.

#### 6.2.1 Error codes



##### Critical Error

In case of a critical error, a function relevant to legal matters is no more proper working. Values may not be used for billing without any pre-evaluation.

---

Critical errors indicate severe problems, but the device can still operate. However, the data measured and stored in the meter may be corrupted and it is recommended that meters showing critical errors are returned to the designated Landis+Gyr service centre.

If the device is displaying the F.F. register with an error code, there is a critical error. If the error register is not cleared, the failure code can be viewed in the installation/service menu or by reading the F.F. register through the communications interface. Critical errors can only be cleared via communication with a reset command.

Due to the temporary nature of communication errors they do not cause the F.F. register to be displayed. However, communication errors get stored in the error register. They are cleared when communication is restored. Communication errors do not usually require meter replacement. These errors do not cause the F.F register to be automatically shown on the display, but are stored in the error register. The meter continues normal operation and does not usually have to be replaced.

##### 6.2.1.1 Representation of error codes

The error code is displayed in the upper line of the display.

## 7 Decommissioning and disposal



### Electronic waste treatment

This product must not be disposed of in regular waste. Use a professional electronic waste treatment process.

The components used to manufacture the device can, in the main, be broken down into constituent parts and sent to an appropriate recycling or disposal facility. When the product is removed from use, the whole product must be sent to a professional electronic waste treatment process. The waste treatment and disposal plants must be approved by local regulatory authorities.

The end processing of the product and recycling of its components must always be carried out in accordance with the rules and regulations of the country where the end processing and recycling are done.

On request, Landis+Gyr will provide more information about the environmental impact of the product.



### Disposal and environmental protection regulations

The following are general guidelines and should not take priority over local disposal and environmental policies, which should be adhered to without compromise.

Components	Disposal
Printed circuit boards	Delivered to recycling plants
Metal components	Sorted and delivered to metal recycling plants
Plastic components	Sorted and delivered to re-granulation if at all possible

## 8 Terms and abbreviations

The following terms and abbreviations are used in this document:

Term	Description
<b>DIN</b>	Deutsche Industrie-Normen.
<b>DSS</b>	Datenschnittstelle. German abbreviation for a data interface.
<b>EEPROM</b>	Electrically Erasable Programmable Read-Only Memory. EEPROM is a type of non-volatile memory used in electronic devices
<b>FNN</b>	Forum Netztechnik/Netzbetrieb. The network technology / network operation forum of the VDE, the German Association for Electrical, Electronic & Information Technologies.
<b>INFO</b>	Optical INFO interface is a standardised interface for the end-user. It is used to communicate with the base meter.
<b>LCD</b>	Liquid Crystal Display.
<b>LED</b>	Light-Emitting Diode.
<b>LMN</b>	Local Metrological Network. LMN provides the communication network between the meter and the gateway. Typically an RS-485 or wireless M-Bus interface.
<b>MCU</b>	Microcontroller Unit. A single computer chip designed for embedded applications.
<b>NIST</b>	National Institute of Standards and Technology. NIST has endorsed elliptic curve cryptography in its set of recommended algorithms for key exchange and digital signature.
<b>OBIS</b>	Object Identification System. OBIS provides standard identifiers for all data within the metering equipment, both measurement values and abstract values.
<b>PIN</b>	Personal Identification Number. PIN is a code asked by the SIM card to authenticate the user.
<b>RAM</b>	Random Access Memory.
<b>RLM</b>	Registered Power Measurement.
<b>SLP</b>	Standard Load Profile.
<b>SMGw</b>	Smart Meter Gateway.
<b>SML</b>	Smart Message Language. SML is a communication protocol for electricity meters.
<b>TLS</b>	Transport Layer Security. TLS is a cryptographic protocol that provides communications security over a computer network.

## 9 Index

Abbreviations.....	36	Operation .....	20
Decommissioning .....	35	Purpose of this manual .....	5
Description of unit .....	8	Reference documents .....	5
Disposal.....	35	Safety.....	6
Disposal regulations.....	35	Information .....	6
Electronic waste treatment .....	35	Regulations.....	6
Environmental protection regulations .....	35	Responsibilities .....	6
Functional overview .....	8	Target group of this manual.....	5
General view .....	8	Technical details.....	10
Installation .....	16	Terms.....	36
Maintenance.....	34	Type designation .....	9
Mechanical construction .....	12	Typographical conventions .....	5

**Contact:**

Landis+Gyr AG

Theilerstrasse 1

CH-6301 Zug

Switzerland

Phone: +41 41 935 6000

[www.landisgyr.com](http://www.landisgyr.com)

Landis  
| Gyr+  
manage energy better